

ORDINANCE NO. 197

**AN ORDINANCE ADOPTING CERTAIN BUILDING PERMIT
FORMS OF THE CITY OF GOSHEN, ARKANSAS INSPECTION
DIVISION**

WHEREAS, the City Council of Goshen has previously granted authority to oversee construction projects to the Office of the Building Inspector of the Inspection Division; and

WHEREAS, the City Council of Goshen desires to adopt certain forms of the Inspection Division as official forms of the City of Goshen, Arkansas; and

NOW, THEREFORE, BE IT ORDAINED BY THE CITY COUNCIL FOR THE CITY OF GOSHEN, ARKANSAS:

SECTION 1. That construction projects require issuance of building permits and inspections of the construction project. The documents attached hereto as Exhibit A contain instructions for issuance of a building permit, the requisite forms, and information and forms pertaining to inspections. The City Council of Goshen hereby adopts said instructions and forms and the official documents required for the issuance of building permits and inspections of construction projects;

SECTION 2. EMERGENCY CLAUSE: It is declared that based on the conditions set forth herein, an emergency exists and this Ordinance, being necessary for the immediate protection of the health, safety, and welfare of the citizens of Goshen, Arkansas, shall be in effect immediately upon its passage, approval, and publication.

PASSED AND APPROVED this 9th day of November, 2021.

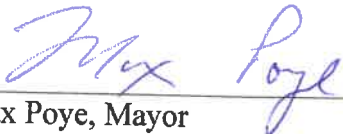

Max Poye, Mayor

ATTEST:

Michael Thompson, Recorder

APPROVED AS TO FORM:

Brian C. Hogue, City Attorney

ROLL CALL

Names of those voting YEA

Paula Anderson
Bill Hewat
Colton Martin
John Vaillancourt
Birch Wright

Names of those voting NAY

Absent

Jamie VanBecelaere

ROLL CALL ADOPTING THE EMERGENCY CLAUSE

Names of those voting YEA

Paula Anderson
Bill Hewat
Colton Martin
John Vaillancourt
Birch Wright

Names of those voting NAY

Absent

Jamie VanBecelaere

City of Goshen

BP #: _____

Site Address: _____

Subdivision and Lot #: _____

RECEIPT # _____
DATE _____
AMOUNT _____

Property Owner

Name: _____

Address: _____

Phone #: _____

Owners Affidavit: Yes No

Water Flow Form: Yes No

Building Contractor

Name: _____

Address: _____

Phone #: _____

Cont. License Copy: Yes No

Receipt #: _____ Date Pd. _____ \$ _____

Inspection Date:

- | | |
|---------------------------|----------------------------|
| _____ 1. FOOTING | _____ 5. INSULATION |
| _____ 2. FOUNDATION WALLS | _____ 6. SIDEWALKS |
| _____ 3. SLAB | _____ 7. DRIVEWAY/APPROACH |
| _____ 4. FRAMING* | _____ 8. FINAL |

Electrical Contractor

Name: _____

Address: _____

Phone #: _____

Cont. License Copy: Yes No

Cont. Liability Ins.: Yes No

Receipt #: _____ Date Pd. _____ \$ _____

Inspection Date:

- | |
|---------------------------------------|
| _____ 1. TEMPORARY CONSTRUCTION METER |
| _____ 2. ROUGH-IN |
| _____ 3. YARD LINE |
| _____ 4. PERM. POWER |
| _____ 5. FINAL |

Mechanical Contractor

Name: _____

Address: _____

Phone #: _____

Cont. License Copy: Yes No

Cont. Liability Ins.: Yes No

Receipt #: _____ Date Pd. _____ \$ _____

Inspection Date:

- | |
|------------------------|
| _____ 1. IN/UNDER SLAB |
| _____ 2. ROUGH-IN |
| _____ 3. FINAL |

GAS Contractor

Name: _____

Address: _____

Phone #: _____

Cont. License Copy: Yes No

Cont. Liability Ins.: Yes No

Receipt #: _____ Date Pd. _____ \$ _____

Inspection Date:

- | |
|-------------------|
| _____ 1. ROUGH-IN |
| _____ 2. AIR TEST |
| _____ 3. FINAL |

Plumbing (Contact City of Fay. or water service provider)

IF WELL

Name: _____

Address: _____

Phone #: _____

Cont. License Copy: Yes No

Cont. Liability Ins.: Yes No

Receipt #: _____ Date Pd. _____ \$ _____

Inspection Date:

- | |
|---------------------------|
| _____ 1. IN/UNDER SLAB |
| _____ 2. ROUGH-IN and/or* |
| _____ 3. FINAL |

6 Month Extension Date: _____

CERTIFICATE OF OCCUPANCY DATE: _____

CITY OF GOSHEN, ARKANSAS
INSPECTION DIVISION
Phone: 479-442-9128 Fax: 479-442-9181
Email: cityhall@cityofgoshen.net
Web: www.cityofgoshen.net

City of Goshen
Instructions for Residential Permit Application

When is a building permit required?

Section 105 of International Building Code:

Any owner or authorized agent who intends to construct, enlarge, alter, repair, move, demolish, or change the occupancy of a building or structure, or to erect, install, enlarge, alter, repair, remove, convert or replace any electrical, gas, mechanical or plumbing system, the installation of which is regulated by this code, or to cause any such work to be done, shall first make application to the building official and obtain the required permit.

Submittals for permit:

1. Complete **Building Permit Application** forms on page 2. Include septic system design approval form from the Washington County Health Department.
2. Complete **Owner/Builder Affidavit** on page 4.
3. If building is new or the footprint of existing building is to be enlarged, submit a **Site Plan** stamped by a registered land surveyor or civil engineer as described on page 5.
4. Submit a **Floor Plan** as described on page 6.
5. Please see the types of proposed outdoor lighting fixtures that meet the **Goshen Lighting Ordinance 107** as explained on pages 7 and 8.
6. See **Required Building Inspections** list on page 9.

Note:

Other permits that may be required include driveway, gas, electric, plumbing, utility/RW and any other applicable permit for the work.

CITY OF GOSHEN, ARKANSAS
INSPECTION DIVISION
 Phone: 479-442-9128 Fax: 479-442-9181
 Email: cityhall@cityofgoshen.net
 Web: www.cityofgoshen.net

BUILDING PERMIT APPLICATION

Building Permit #: _____

A DUMPSTER & PORTA POTTY ARE REQUIRED AT ALL CONSTRUCTION SITES. BURNING OF CONSTRUCTION MATERIAL IS PROHIBITED. CONTACT THE GOSHEN FIRE DEPT FOR ALL OTHER BURN PERMITS.

SITE ADDRESS: _____ ZONE: _____

LOT NUMBER AND SUBDIVISION: _____

Property Owner: _____ Mailing Address: _____

Phone: _____

Contractor: _____ Mailing Address: _____

Phone: _____ Contractor's License Number: _____ Expiration Date: _____

Architect: _____ Mailing Address: _____ Phone: _____

Engineer: _____ Mailing Address: _____ Phone: _____

TYPE: Residential (*single family only*): _____ Commercial: _____ Other: _____

CLASS OF WORK: New: _____ Addition: _____ Alteration: _____ Repair: _____ Move: _____ Demolition: _____

BUILDING INFORMATION

| | | |
|---------------------|---|--------------------------------|
| # of Stories: _____ | Sum Total Area: _____ sq. ft. | Slab Floor: _____ Yes _____ No |
| Height: _____ | Total Heated/Cooled: _____ sq. ft. | Basement: _____ sq. ft. |
| Length: _____ | Total Unheated: _____ sq. Ft. | Add/Alt Area: _____ sq. ft. |
| Width: _____ | Structure: _____ Wood: _____ Metal: _____ Masonry: _____ Other: _____ | |

TOTAL ESTIMATED VALUATION: \$ _____

Is a retaining wall to be constructed: ___ Yes ___ No Will an automatic sprinkler system be provided? ___ Yes ___ No

Flood Plain? ___ Yes ___ No Base Flood Elevation: _____ Lowest Finished Floor: _____

Washington County Septic Approval Number: *** _____ New Residential Driveway: ___ Yes ___ No

Attach copy of approval form

COMPLIANCE WITH DRIVEWAY ORDINANCE _____

NOTICE

SEPARATE PERMITS ARE REQUIRED FOR ELECTRICAL, PLUMBING, GAS, AND MECHANICAL. THIS PERMIT BECOMES NULL AND VOID IF WORK/CONSTRUCTION AUTHORIZED IS NOT COMMENCED WITHIN SIX (6) MONTHS OR IF WORK/CONSTRUCTION IS SUSPENDED OR ABANDONED FOR A PERIOD OF SIX (6) MONTHS.

I hereby certify that I have read and examined this application and know the same to be true and correct. All provisions of law and ordinances governing this type of work will be complied with whether specified herein or not. The granting of a permit does not presume to give authority to violate or cancel the provisions of any other state or local law regulating construction or the performance of construction.

Signature of Property Owner/Contractor/Authorized Agent _____ Print Name _____ Date _____

Signature of Inspection Division, City of Goshen _____ Date _____

OFFICE USE ONLY

Zone / Primary Use _____

Zoning Official Signature _____

CITY OF GOSHEN, ARKANSAS
INSPECTION DIVISION
Phone: 479-442-9128 Fax: 479-442-9181
Email: cityhall@cityofgoshen.net
Web: www.cityofgoshen.net

CERTIFICATE OF ZONING COMPLIANCE

ALL WORK MUST MEET WITH CITY OF GOSHEN CODES AND ORDINANCES.
SITE PLANS MUST BE SUBMITTED WITH THIS APPLICATION.

Property located in Goshen zone _____

CONTRACTOR'S NAME: _____ PHONE NUMBER: _____

ADDRESS: _____

OWNER'S NAME: _____ ADDRESS: _____

SITE LOCATION: _____ ZONE: _____
(STREET ADDRESS)

LOT NUMBER AND SUBDIVISION: _____
(OR LEGAL DESCRIPTION)

LOT AREA: _____ SETBACKS: FRONT _____ REAR _____ SIDE _____

PROPOSED USE: _____

ACCESSORY USE: _____ LOT COVERAGE: _____

SIGNAGE: _____
(NUMBER, SIZE, TYPE, LOCATION, ETC.)

SIGNATURE OF APPLICANT

DATE

PLANNING COMMISSION APPROVAL REQUIRED: _____ YES _____ NO

CORRECTION LIST: _____

____ APPROVED _____ DENIED

____ APPROVED _____ NO

Date: _____

Date: _____

Planning Commission, if applicable

Zoning Official

CITY OF GOSHEN, ARKANSAS
INSPECTION DIVISION
Phone: 479-442-9128 Fax: 479-442-9181
Email: cityhall@cityofgoshen.net
Web: www.cityofgoshen.net

OWNER/BUILDER AFFIDAVIT

Arkansas State law requires an Arkansas State Residential License for certain residential buildings.

A property owner who acts as a residential building contractor for the purpose of constructing his/her own residence is not required to be licensed unless said person constructs more than one (1) residence per calendar year.

PROPERTY ADDRESS: _____

Now, on this _____ day of _____, 20____, I, _____,

(Please print your name)

declare that I am applying for a building permit for the above described property; that I will be responsible for performing the work and meeting the requirements of all codes, ordinances, and laws; that I am the owner of the above described property; that I am the occupant of the property; and that the use of the property is by the owner as a single family residence. Therefore, I am not required to have an Arkansas State Residential License.

Owner Signature

Print Name

Date

NOTE: Arkansas law now requires a residential builder (which includes a project manager or a construction manager) to have a Residential License to build one residence.

CITY OF GOSHEN, ARKANSAS
INSPECTION DIVISION
Phone: 479-442-9128 Fax: 479-442-9181
Email: cityhall@cityofgoshen.net
Web: www.cityofgoshen.net

RESIDENTIAL SITE PLAN REQUIREMENTS

Site plans must be drawn to one of the following conventional scales by registered surveyor or civil engineer. Submit two hard copies in engineer's scale (1"=10', 1"=20', etc.) or architect's scale (1/8"=1', 1/4"=1', etc.).

For clarity, Site Plans of large properties may have to be in two parts – one Site Plan for the entire property and one Site Plan for the immediate location of the structure to be built or remodeled. Site plans which are not legible or do not scale properly when reviewed may not be accepted.

Site plans must show the following:

- Street Address and applicable Zone
- Subdivision Name and Lot Number (if applicable)
- Lot boundaries with dimensions of all existing and proposed structures or additions
- Street Rights-of-way -measured from centerline of street
- Required Zoning Setbacks
- Proposed Setbacks -measured from roof overhangs
- Utility easements and all existing and proposed utility locations
- Location of overhead or underground electrical Lines
- Direction of drainage from impervious surfaces and any altered water flows
- Access Easements
- Access Drives
- Sidewalks
- Driveways and curb cuts
- Location of porta-potty, dumpster and concrete washout
- Floodplain Limits
- Streamside Protection Zones

CITY OF GOSHEN, ARKANSAS
INSPECTION DIVISION
Phone: 479-442-9128 Fax: 479-442-9181
Email: cityhall@cityofgoshen.net
Web: www.cityofgoshen.net

RESIDENTIAL FLOOR PLAN REQUIREMENTS

Submit one (1) copy of a Floor Plan at scale of ¼" per foot minimum. Identify the names of all rooms and dimensions on the Floor Plan and fill in form below:

Address: _____

Overall Building Area: _____

Electric Meter and Main Disconnect Location: _____

Electric Panel Location: _____

Furnace Location: _____

Exterior AC Unit Location: _____

Water Heater Location and fuel type _____

Fireplaces: ___ Gas ___ Wood ___ N/A

Interior Stairs: Tread width _____ Riser Height _____

Entry Steps: Tread width _____ Riser Height _____

Handrails Height: _____ inches Guardrails Height: _____ inches

Egress Windows Size and Location: _____

Attic Access Location and Size: _____

Garage Door Header Size, material and length: _____

Include any decks, porches or patios, where proposed. _____

Insulation value for Floor R- _____ Walls R- _____ Ceiling R- _____

Separate plumbing, electrical, mechanical, gas and/or grading permits may be required.

**CITY OF GOSHEN, ARKANSAS
INSPECTION DIVISION**

Phone: 479-442-9128 Fax: 479-442-9181

Email: cityhall@cityofgoshen.net

Web: www.cityofgoshen.net

The City of Goshen, Arkansas, in an effort to maintain our rural flavor, has an Outdoor Lighting Ordinance (107). The intent is to promote use of shielded light fixtures that direct light downward to minimize light pollution and enhance the enjoyment of our night sky. An important benefit of directing light downward only on the area where illumination is needed is to keep it within your property boundaries and to avoid light trespass onto your neighbor's property and unintended glare.

To further minimize harmful effects of light pollution, use bulbs with a warm color temperature of 3000K or less (shown on bulb package). If you would like to learn more about this and other outdoor lighting topics, visit www.darksky.org.

Your neighbors thank you for your help and compliance as we 'share the stars' of Goshen.

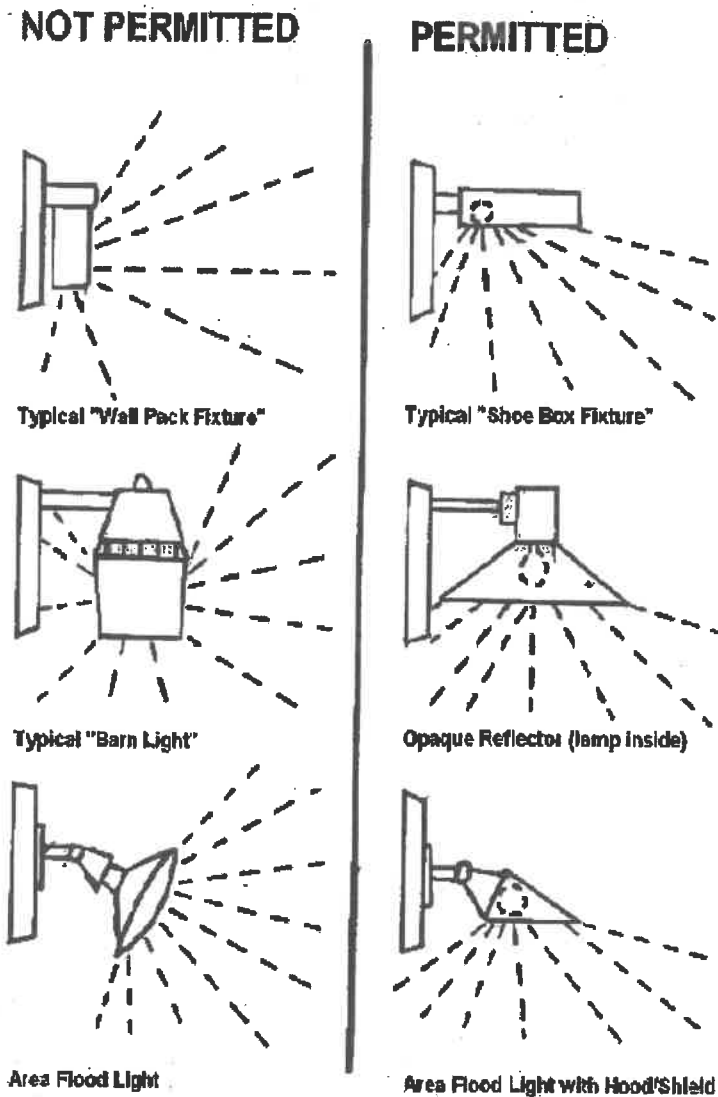

CITY OF GOSHEN, ARKANSAS
INSPECTION DIVISION
Phone: 479-442-9128 Fax: 479-442-9181
Email: cityhall@cityofgoshen.net
Web: www.cityofgoshen.net

MODIFYING EXISTING FIXTURES

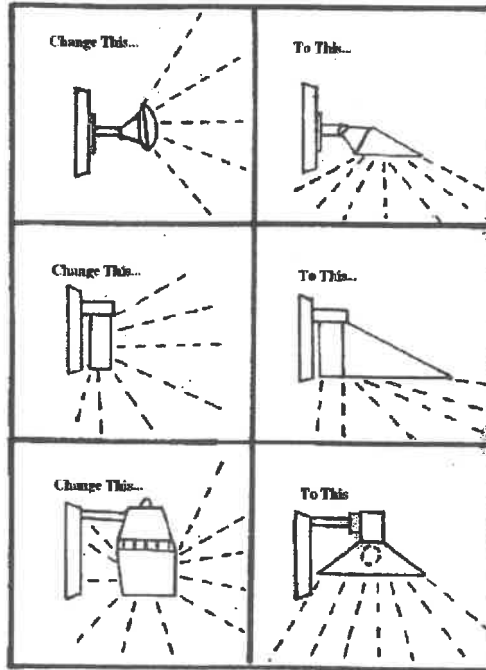

CITY OF GOSHEN, ARKANSAS
INSPECTION DIVISION
Phone: 479-442-9128 Fax: 479-442-9181
Email: cityhall@cityofgoshen.net
Web: www.cityofgoshen.net

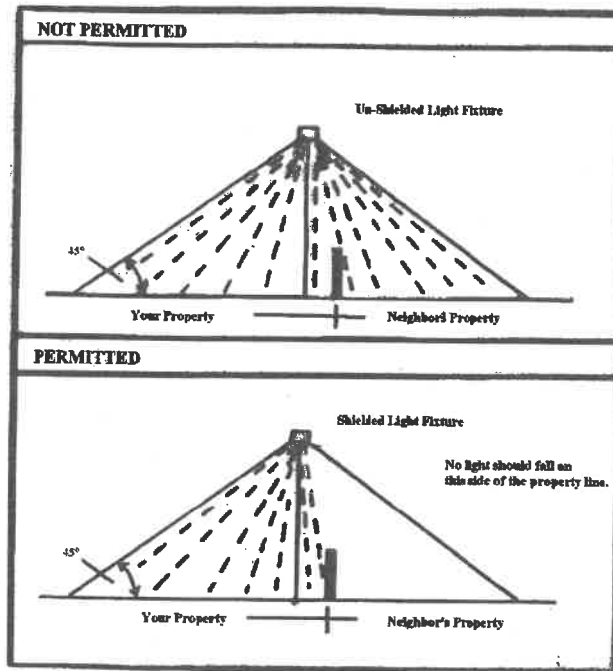

page 8

REQUIRED BUILDING INSPECTIONS

BUILDING

1. FOOTING
2. FOUNDATION WALLS
3. SLAB
4. FRAMING*
5. INSULATION*/FINAL

PLUMBING

Contact the City of Fayetteville
or water service provider

MECHANICAL

1. IN/UNDER SLAB
2. ROUGH-IN and/or*
3. FINAL

ELECTRICAL

1. TEMPORARY CONSTRUCTION METER
2. UNDERGROUND
3. IN/UNDER CONCRETE
4. ROUGH-IN*
5. FINAL

GAS

Under Construction, Contact Building
Official for further information.
Goshen is now providing all natural gas
inspections excluding propane

PUBLIC SIDEWALK/DRIVE APPROACH

1. INSPECTION REQUIRED BEFORE
CONCRETE POURED
2. FINAL

* DUMPSTER & Porta Potty required at each job site.

CITY OF GOSHEN, ARKANSAS
INSPECTION DIVISION
Phone: 479-442-9128 Fax: 479-442-9181
Email: cityhall@cityofgoshen.net
Web: www.cityofgoshen.net

ORDER OF BUILDING INSPECTIONS:

- (1) Electrical-Temporary Construction Meter
- (2) Building-Footing
- (3) Building-Foundation walls (Basements)
- (4) Building-Slab; Mechanical-In/Under Slab; Electrical-In/Under Concrete
- (5) Building-Framing; Mechanical-Rough-in; Electrical-Rough-in, including Underground, Gas
- (6) Insulation
- (7) Final in all areas and insulation

NOTE: There will be a \$20.00 fee for all re-inspections. All re-inspection fees must be paid at City Hall, 124 S. Church St, prior to re-inspection. Separate fees will be charged for each trade involved.

SITE DRAINAGE, DRIVEWAY, CURB CUT, AND SIDEWALL SHALL BE COMPLETE AND WILL BE INSPECTED ON FINAL INSPECTION. DRIVEWAYS MUST BE INSPECTED PRIOR TO POUR; @) MIN SETBACK REQUIRED AT APRON FOR a DEPTH OF 15 feet.

MAILBOX SUPPORTS SHALL NOT INTERFERE WITH REQUIRED SIDEWALK DEPTH.

Inspections will be made by the Inspection Division as required to ensure all requirements are completed and building and site improvements conform to codes, ordinances, and laws before Certificate of Occupancy is executed and issued.